



Air comfort for all



# QUICK START GUIDE

## Cold Climate Heat Pump

Thank you for choosing our product.  
Please read this Quick Start Guide carefully before  
operation and retain it for future reference.

# PLEASE READ FIRST

Although very similar to traditional unitary heat pump systems, the FLEXX Heat Pump Systems have a few key installation differences.

1. **Each outdoor unit has two capacity and blower settings available on their corresponding control boards. (Detailed on the next page)**
  - The 36kBtu models are rated for either 24kBtu or 36kBtu, nominal.
  - The 60kBtu models are rated for either 48kBtu or 60kBtu, nominal.
  - The efficiency ratings may change with a change in the capacity rating.
  - The outdoor and indoor capacities must match.
2. **Evacuation**
  - The indoor unit contains a nitrogen charge on the R32 version of the FLEXX
  - When evacuating (pulling a vacuum), **pull from both the liquid and gas (suction) valves.** This will ensure a proper evacuation has been performed and no air or moisture are in the refrigeration system. This will also mean proper evacuation takes less time.
3. **The “H1/H2” RS485 Communication terminals**
  - The H1/H2 terminals are recommended to always be connected at the Indoor and Outdoor unit.
  - When using 24V control with H1/H2 NOT connected. Dip Switches must be changed at the Outdoor and Indoor unit. see page 4 for Dip Switch settings.
  - It is HIGHLY recommended to use a separate cable for H1/H2 (separate from any 24V cable)
4. **This system contains PVE oil, not POE. Cross-contamination is prohibited.**
  - Replace or flush existing line sets and/or coils in a retrofit application
5. **The blower speed must be set according to the blower charts regardless of whether you choose to use RS485 or 24V control (see pages 9-11)**

 **DO NOT DISCARD. STORE THIS INFORMATION IN A SAFE PLACE FOR FUTURE REFERENCE.**

## REFRIGERANT LEAKAGE SENSOR

It is REQUIRED to adjust the refrigerant leak sensor location when installing the air handler in a horizontal right application. Please see the illustration below.



Refrigerant leakage sensor

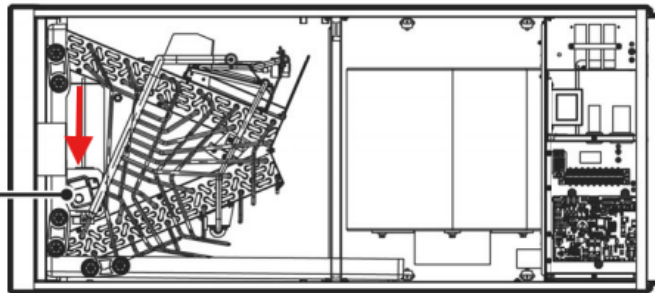

# OUTDOOR UNIT DIP SWITCH SETTINGS



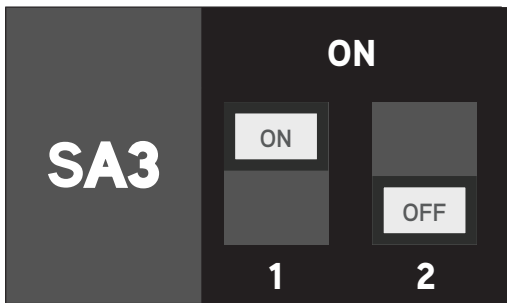

## NOTE

- FLEXX outdoor units are configurable by a set of dip switches located on the Main Control Board.
- By default, the capacity is set at the larger capacity.
- Power must be shut off prior to changing the dip switch settings.
- The outdoor unit capacity must match the indoor unit capacity.
- Default setting is RS485 Comm. The H1/H2 terminals must be connected at the indoor and outdoor unit or E6 will result. If 24V control is used the dip switches only need to be changed at the Outdoor and Indoor units when H1/H2 are NOT connected

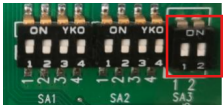

## NOTE

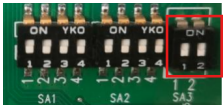
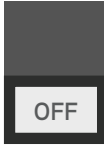
The ON position of the switch is towards the word "ON" located on the dip switch bank.

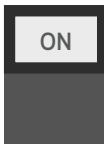
Capacity	SA3 DIP#2	Capacity	SA3 DIP#2
 FXU36HP230V1R32AO 36kBtu Configuration (Default)		 FXU60HP230V1R32AO 60kBtu Configuration (Default)	
24kBtu Configuration		48kBtu Configuration	

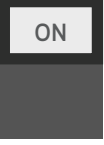
24V / RS485 COMM SA1	SA1 DIP#1
FXU36HP230V1R32AO RS485 Comm (Default) H1/H2 Connected	
FXU60HP230V1R32AO 24V control	

## NOTE

See page 8 for Indoor dip switch setting. Both SA1 #1 IDU & ODU Dips must be set the same for either 24V or RS485.

# OUTDOOR UNIT DIP SWITCH SETTINGS

**NOTE**

- FLEXX outdoor units are configurable by a set of dip switches located on the Main Control Board.

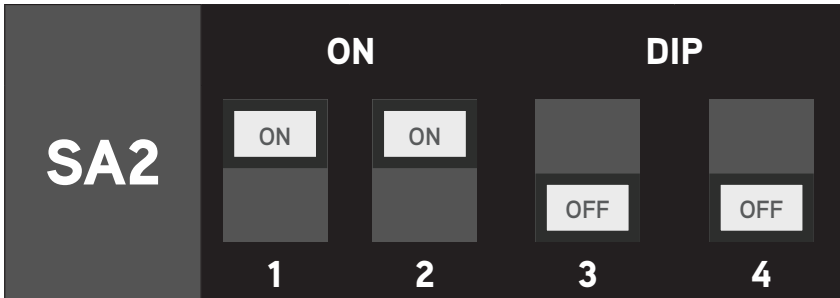

**NOTE**

The ON position of the switch is towards the word "ON" located on the dip switch bank

Defrost SA2		SA2 DIP#1 & 2		Operating Modes SA1		DIP#3	DIP#4
FXU36HP230V1R32AO FXU60HP230V1R32AO	Standard (Default)			FXU36HP230V1R32AO FXU60HP230V1R32AO	Standard (Default)		
	Strong Defrost				Energy Saving		
Noise Reduction Mode SA2		SA2 DIP#3 & 4		FXU36HP230V1R32AO FXU60HP230V1R32AO	Strong Mode		
FXU36HP230V1R32AO FXU60HP230V1R32AO	Standard (Default)				Adaptive Mode		
	Mode 1				Mode 2		
	Mode 2					Mode 3	

## DEFROST

- **Standard Defrost Mode** is the default setting from the factory.
- **Strong Defrost Mode** is used in cold but high humidity environments such as areas near large bodies of water. Select Strong Defrost Mode if it is common practice to extend defrost timing or increase the frequency of defrost cycles in the area where the system is installed.
- In other cases where Standard Defrost Mode has been deemed insufficient, ensure the system is in good working order, the outdoor coil is clean, and the system is charged properly before changing the defrost setting to Strong Defrost Mode.

## STRONG MODE

- In **Strong Mode**, the compressor will increase its speed at a higher rate than in **Standard Mode**, to reduce the ramp up time.
- **Strong Mode** may be enabled if **Standard Mode** is deemed insufficient by the customer but note it is less efficient.
- Always ensure the system is in good working order before enabling **Strong Mode**.

## ENERGY SAVING MODE

- In **Energy Saving Mode**, the compressor will increase its speed at a lower slower rate. This can increase efficiency of the unit and provide additional dehumidification than the **Standard** or **Strong** modes.
- Example: **Energy Saving Mode** may be used when the new system is replacing a system that was a half-ton smaller than the FLEXX being installed. (The FLEXX is not available in 1.5, 2.5 or 3.5 ton capacities, therefore FLEXX would be set for the next highest capacity such as 2, 3 or 4 ton.)
- The indoor CFM rating should also be reduced to match a normal CFM rating for the half-ton system design. This would mean that the set point would most likely be satisfied before reaching the system's full rated nominal capacity, reducing energy usage and improving dehumidification in cooling mode.

### NOTE

Strong Mode and Energy Saving Mode cannot be enabled at the same time. Only one mode can be enabled.

# REFRIGERANT CHARGING

- It is recommended to install a new 3/8" X 3/4" line set.
- Filter driers are not recommended. Follow industry best practices for refrigerant piping.

FLEXX 2/3 Ton - FXU36HP230V1R32AO	
Total Length of Line Set:	Add <sup>1</sup> :
31 feet and Below	None
32 - 34 feet	1 oz.
35 - 37 feet	1.9 oz.
38 - 40 feet	2.9 oz.
41 - 43 feet	3.9 oz.
44 - 46 feet	4.9 oz.
47 - 49 feet	5.8 oz.
50 - 52 feet	6.8 oz.
53 - 55 feet	7.8 oz.
56 - 58 feet	8.7 oz.
59 - 61 feet	9.7 oz.
62 - 64 feet	10.7 oz.
65 - 67 feet	11.6 oz.
68 - 70 feet	12.6 oz.
71 - 73 feet	13.6 oz.
74 - 76 feet	14.6 oz.
77 - 79 feet	15.5 oz.
80 - 82 feet	1 lb 0.5 oz.
83 - 85 feet	1 lb 1.5 oz.
86 - 88 feet	1 lb 2.4 oz.
89 - 91 feet	1 lb 3.4 oz.
92 - 94 feet	1 lb 4.4 oz.
95 - 97 feet	1 lb 5.3 oz.
98 - 100 feet	1 lb 6.3 oz.
101 - 103 feet	1 lb 7.3 oz.
104 - 106 feet	1 lb 8.3 oz.
107 - 109 feet	1 lb 9.2 oz.
110 - 112 feet	1 lb 10.2 oz.
113 - 115 feet	1 lb 11.2 oz.
116 - 118 feet	1 lb 12.1 oz.
119 - 121 feet	1 lb 13.1 oz.
122 - 124 feet	1 lb 14.1 oz.
125 - 127 feet	1 lb 15 oz.
128 - 130 feet	2 lb
131 - 133 feet	2 lb 1 oz.
134 - 136 feet	2 lb 2 oz.
137 - 139 feet	2 lb 3 oz.
140 - 142 feet	2 lb 4 oz.
143 - 145 feet	2 lb 5 oz.
146 - 148 feet	2 lb 5.8 oz.
149 - 151 feet	2 lb 6.8 oz.
152 - 154 feet	2 lb 7.8 oz.
155 - 157 feet	2 lb 8.7 oz.
158 - 160 feet	2 lb 9.7 oz.
161 - 164 feet	2 lb 11 oz.
<b>164 Feet is Max. Length</b>	

FLEXX 4/5 Ton - FXU60HP230V1R32AO	
Total Length of Line Set:	Add <sup>2</sup> :
31 Feet and Below	None
32 - 36 feet	1.1 oz.
37 - 41 feet	2.2 oz.
42 - 46 feet	3.2 oz.
47 - 51 feet	4.3 oz.
52 - 56 feet	5.4 oz.
57 - 61 feet	6.5 oz.
62 - 66 feet	7.6 oz.
67 - 71 feet	8.6 oz.
72 - 76 feet	9.7 oz.
77 - 81 feet	10.8 oz.
82 - 86 feet	11.9 oz.
87 - 91 feet	13 oz.
92 - 98 feet	14.7 oz.
<b>98 Feet is Max. Length</b>	

#### Additional Refrigerant Charge Calculation

1. 0.32 oz/ft for 2 & 3 Ton Systems
2. 0.22 oz/ft for 4 & 5 Ton Systems

# COLD WEATHER STARTUP

The FLEXX outdoor unit is factory equipped with a crankcase heater.

- In outdoor temperatures below 32°F (0°C), ensure that power is applied to the outdoor unit for a minimum of 8 hours prior to startup.
- Upon power application, check the operation of the crankcase heater by removing the front access panel, opening the compressor blanket, and checking to see if the crankcase heater is hot.
- The crankcase heater ensures that liquid refrigerant is not present in the compressor before startup.
- Liquid refrigerant is not compressible and will force the compressor oil out of the compressor. This will damage the compressor.

## INSTALLATION TIP

To make the best use of the 8 hour preheat, do the following:

1. Set the outdoor and indoor units
2. Install the refrigerant piping
3. Perform a leak check
4. Pull a 500 micron vacuum
5. Connect line voltage to the outdoor unit
6. Weigh in additional charge, if needed
7. Open the indoor and outdoor shutoff valves
8. Power on the outdoor unit
9. Complete all other installation items once power is applied to the outdoor unit

# AIR HANDLER DIP SWITCH SETTINGS

## NOTE

- The R32 FLEXX Air Handlers fan speed must be set regardless of RS485 or 24V control for proper operation, ensure that the air handler blower settings match the outdoor unit capacity and ducting design. Power must be off prior to changing the dip switch settings.
- There are 5 static pressure settings for the blower.
- Air handler's Dip Switches are located on the Main Control Board inside the air handler control box.
- By default, the blower is set at Speed 3.
- Dip switch settings are on the following two pages.
- As with all air handling equipment, a duct system with a design that exceeds the capabilities of the installed equipment will result in customer discomfort, limited performance, and reduced equipment life.

24V/RS485 COMM SA1		SA1 DIP#1
FXU**HP230V1R32AH	RS485 Comm (Default) H1/H2 Connected	
FXE**HP230V1R32AH	24V control	

Model	FXU**HP230V1R32AH	
	HEAT (SA2)	COOL (SA1)
Speed 1		
Speed 2		
Speed 3 (Default)		
Speed 4		
Speed 5		

## NOTE

Only the "HEAT (SA2)" Dip switches are adjusted for fan setup.

# CHECKING STATIC PRESSURE

To properly utilize the below fan charts it is required to determine Total Static.

- Supply static must be measured in the supply trunk after the air handler and before branch ducts or registers in the airflow stream as shown in the figure above
- Return static must be measured in the return trunk towards the air handler after any branch returns, return grilles or filters
- Keep in mind static pressure drop will increase with a wet coil (cooling mode) vs dry coil (fan on or heating mode)

## NOTE

- Total static includes everything the air handler is working against, supply duct return duct, branch duct, register boots, elbows, filter grille, filter and so on.
- Total Static is the difference between supply positive pressure and return negative pressure.

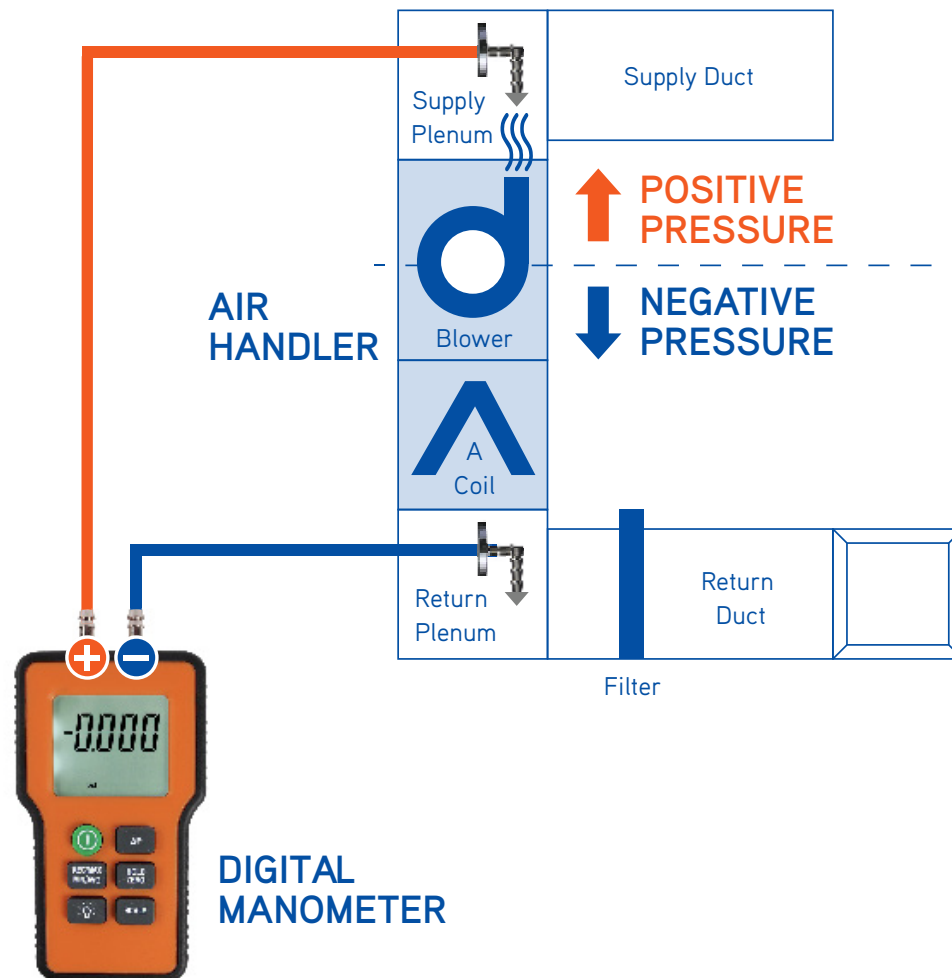

# AIR HANDLER AIRFLOW RATINGS

The following CFM ratings are with a dry coil and included filter. For wet coil ratings, use 0.92 as the correction factor for the CFM.

Model	FXU24HP230V1R32AH											
Level	Static Pressure (In W.c.) and CFM											
	0	0.1	0.15	0.2	0.3	0.4	0.5	0.6	0.7	0.8	0.9	1.0
Speed 1	1080	960	830	-	-	-	-	-	-	-	-	-
Speed 2	1220	1120	1060	990	820	-	-	-	-	-	-	-
Speed 3	1380	1250	1120	1070	1020	920	760	-	-	-	-	-
Speed 4	1700	1630	1580	1530	1450	1400	1370	1270	1150	970	790	-
Speed 5	1750	1700	1650	1600	1590	1500	1420	1330	1200	1050	950	850

Model	FXU36HP230V1R32AH											
Level	Static Pressure (In W.c.) and CFM											
	0	0.1	0.15	0.2	0.3	0.4	0.5	0.6	0.7	0.8	0.9	1.0
Speed 1	1220	1120	1020	960	-	-	-	-	-	-	-	-
Speed 2	1380	1260	1200	1100	950	-	-	-	-	-	-	-
Speed 3	1630	1580	1500	1430	1370	1200	1000	970	-	-	-	-
Speed 4	1840	1800	1750	1710	1640	1590	1500	1420	1330	1220	1100	930
Speed 5	1870	1830	1810	1800	1760	1690	1620	1520	1440	1350	1250	1150

Model	FXU48HP230V1R32AH											
Level	Static Pressure (In W.c.) and CFM											
	0	0.1	0.15	0.2	0.3	0.4	0.5	0.6	0.7	0.8	0.9	1.0
Speed 1	1680	1560	1500	1350	-	-	-	-	-	-	-	-
Speed 2	1810	1690	1620	1550	1380	-	-	-	-	-	-	-
Speed 3	1930	1830	1770	1710	1580	1480	1200	-	-	-	-	-
Speed 4	2280	2240	2200	2180	2130	2080	2000	1880	1750	1600	1400	1200
Speed 5	2300	2260	2220	2190	2140	2090	2040	1980	1930	1800	1700	1550

Model	FXU60HP230V1R32AH											
Level	Static Pressure (In W.c.) and CFM											
	0	0.1	0.15	0.2	0.3	0.4	0.5	0.6	0.7	0.8	0.9	1.0
Speed 1	1850	1720	1650	1600	-	-	-	-	-	-	-	-
Speed 2	1920	1800	1730	1650	1480	-	-	-	-	-	-	-
Speed 3	2110	2000	1950	1860	1760	1640	1500	-	-	-	-	-
Speed 4	2300	2260	2230	2200	2150	2115	2050	1990	1920	1790	1650	1470
Speed 5	2320	2280	2250	2230	2190	2140	2080	2040	2000	1950	1920	1890

# 24V CONTROL WIRING SCHEMATIC

24V Control using any Heat Pump T-Stat

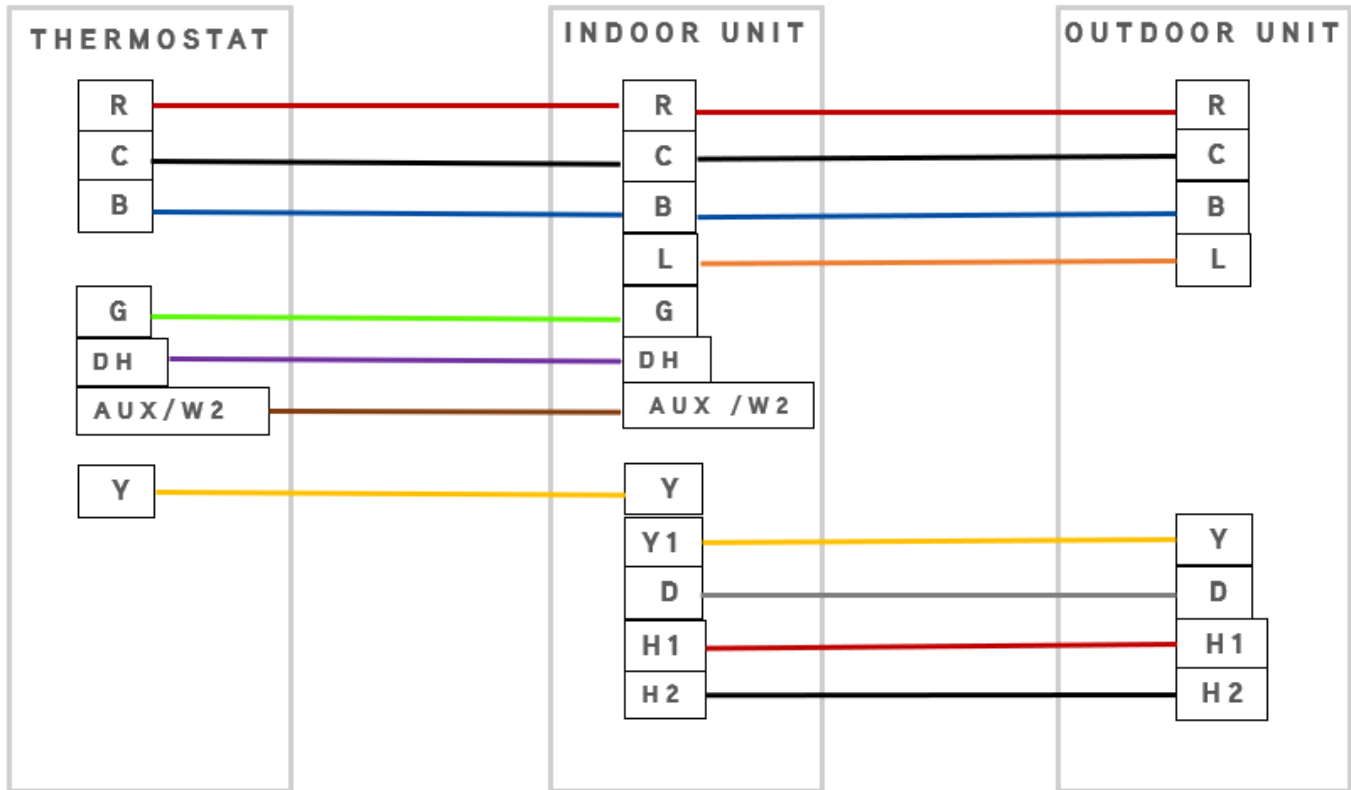

It is highly recommended to use a separate cable for H1/H2

## NOTE

- L should always be connected-this is the refrigerant leakage shutdown signal.
- Y Is for compressor call from the thermostat.
- Y1 Is the output signal from the indoor to the outdoor Y provided there is no leak detection.
- B is to energize the RV in heating mode.
- D is the defrost signal to shut off blower during defrost when electric heat is not on.
- W2/Aux accepts second stage call from the thermostat to run electric heat with the HP.
- DH is for dehumidification signal from the thermostat.
- H1 & H2 are RS485 connections for communication between IDU & ODU. These are also used for the GREE controller if desired- always connect between IDU & ODU even when using 24V control.
- It is HIGHLY recommended to use a separate cable for H1/H2.

# RS485 CONTROL WIRING SCHEMATIC

Using GREE Controller WK-010WC1 Part# NC20700410

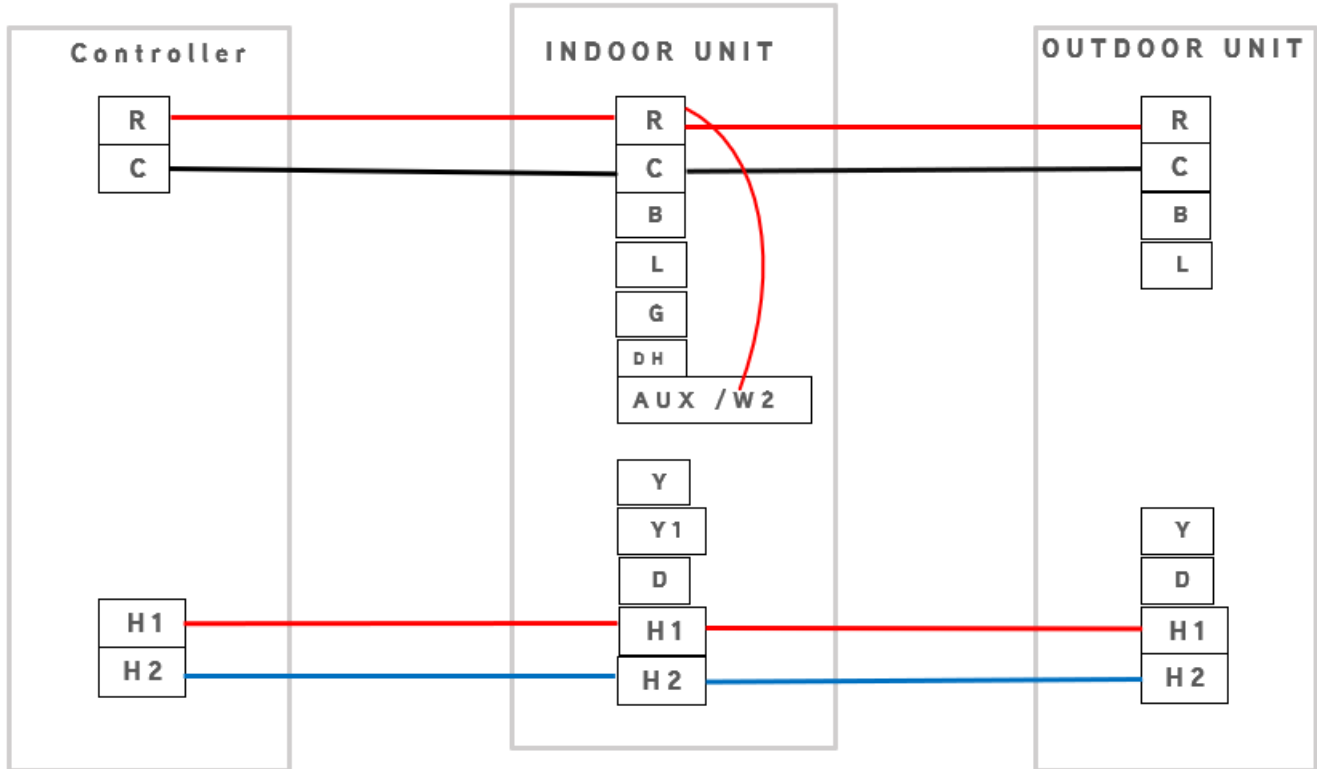

It is highly recommended to use a separate cable for H1/H2

## NOTE

- It is HIGHLY recommended to install a separate cable for H1/H2
- 24V hot (R) and 24V Common (C) are required to power the controller

## FIELD INSTALLED TRANSITION-DUAL FUEL

It is recommended to add a Field-installed Transition when the coil does not have same dimensions as the furnace. Please see the illustration below.

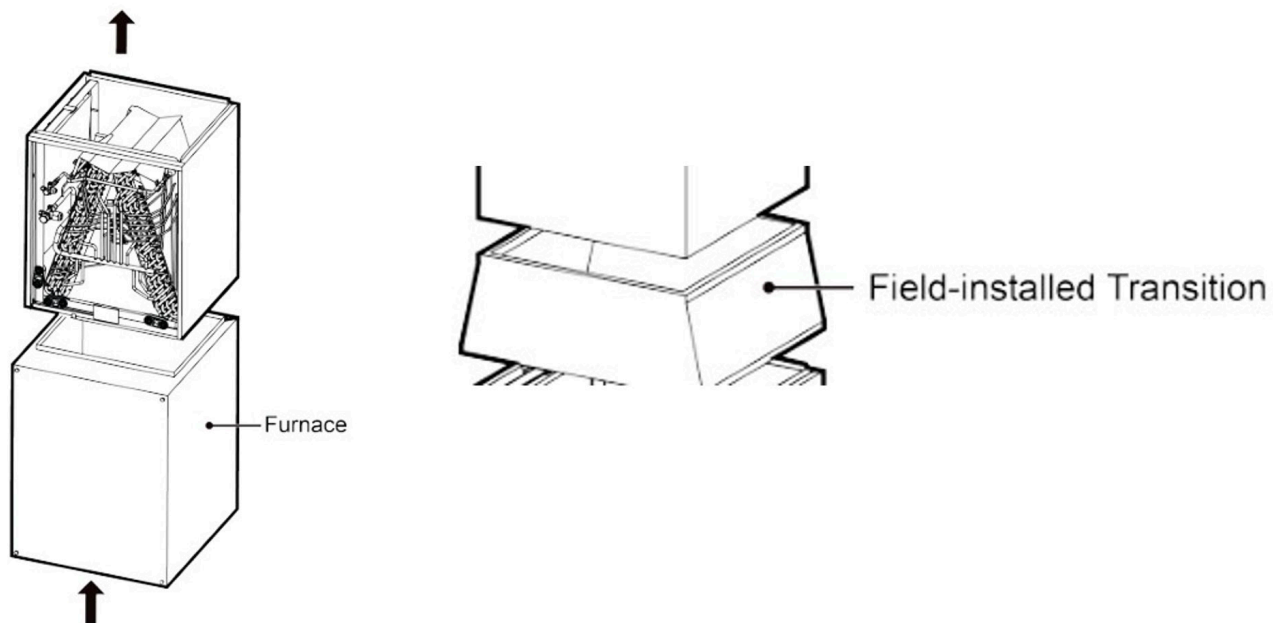

### NOTE

Adding a proper Field-installed Transition will ensure proper airflow across the entire coil and allow space for inspecting the coil and heat exchanger.



Air comfort for all

U.S. CONTACT INFORMATION TRADEWINDS, LLC

E-mail: [info@twclimate.com](mailto:info@twclimate.com)

Contractor Support: 888-850-7928 | Mon-Fri 8 AM - 5 PM EST

[GREECOMFORT.COM](http://GREECOMFORT.COM)

---